

4  
DRAWING MADE IN THIRD ANGLE PROJECTION

© COPYRIGHT 1968 BY AMP INCORPORATED, HARRISBURG, PA.  
ALL INTERNATIONAL RIGHTS RESERVED. AMP INCORPORATED PRODUCTS  
COVERED BY U. S. AND FOREIGN PATENTS AND/OR PATENTS PENDING.

REVISIONS					
P	ZONE	LTR	DESCRIPTION	DATE	APPROVED
✓		A	REDRAWN & REVISED A-3943 L.M.	1/5/78	SS/
✓		B	REVISED AFD169	5/15/84	584/64
✓		C	OBS. - 4 AF-1556	7/10/86	7/1/84
✓		D	OBS. - 1 AF-3662	5/16/88	7ms/64
✓		E	REV PER AF-6785	7/5/90	PMF/94
✓		F	REV PER 0110-0090-97	2/16/87	PMF/64

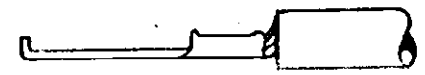

FLANGED IN APPLICATOR

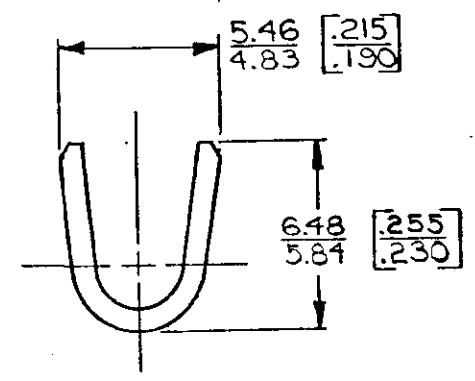
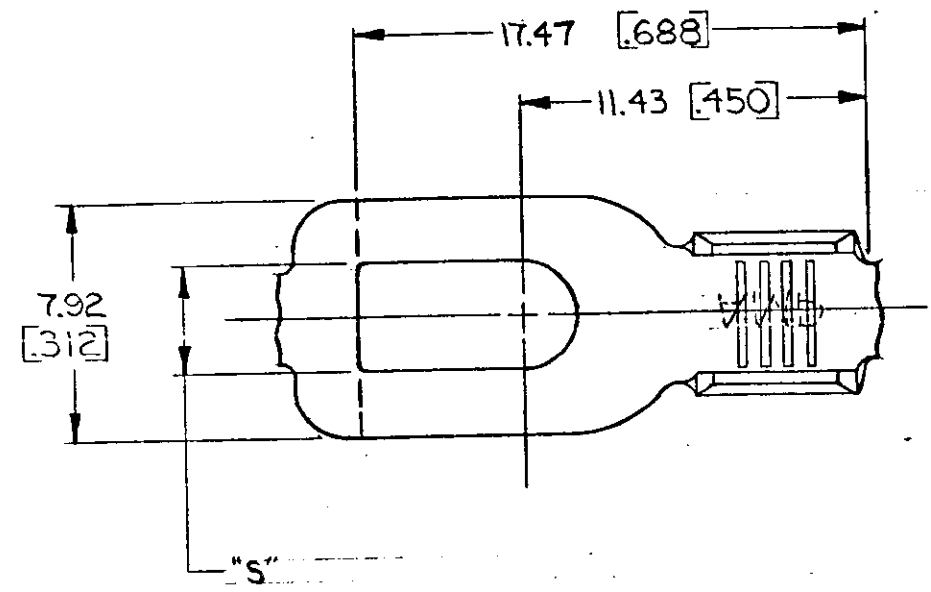

SECT A-A

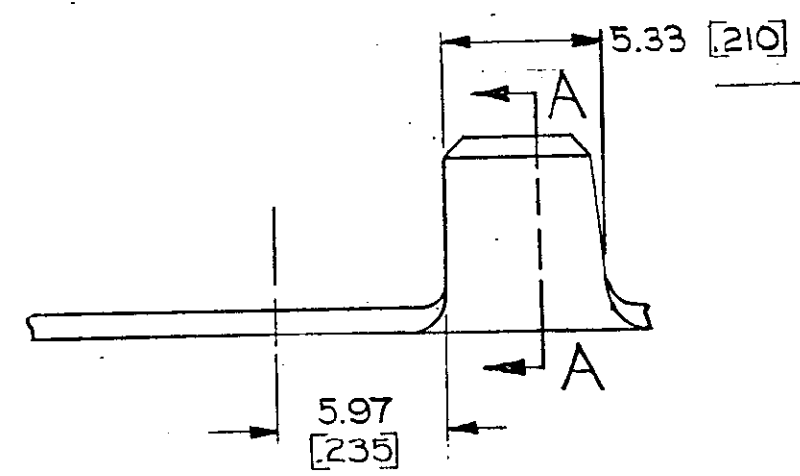

4.34 [.71]	M 4 #8	↑	SILVER	↑	42113-4A 42113-4
3.68 [.45]	M 3.5 #6				
4.34 [.71]	M 4 #8	3.0-5.0 mm <sup>2</sup> [2-10]	TIN	↑	42113-3A 42113-3
3.68 [.45]	M 3.5 #6				
"S" ±0.07 [003]	STUD SIZE	WIRE RANGE	FINISH	0.76 [030] BRASS	42113-2A 42113-2
					42113-1A 42113-1
					PART NO

- △ SUFFIX LETTER MUST BE USED ONLY WHEN ORDERING APPLICATOR TOOLING
- CONTINUOUS STRIP ON REELS.
  - DIMENSIONS IN BRACKETS ARE IN INCHES

**METRIC**

UNLESS OTHERWISE SPECIFIED DIMENSIONS ARE IN mm TOLERANCES ON: DECIMALS ±0.38 [015] ANGLES ±1°		CONTRACT NO		AMP INCORPORATED Harrisburg, Pa.	
MATERIAL SEE TABLE		DR <i>L. Magano</i> 5/1/78			
FINISH SEE TABLE		CHK <i>S. Schaff</i> 11/20/78		NAME SPADE	
		APPR <i>R.D. Frantz</i> 8-10-78		SIZE B	
		APPR <i>E. Zucko</i> 8-10-78		CODE IDENT NO 00779	
		DSGN APPD		DRAWING NO 42113	
		OTHER APPD		SCALE	
				SHEET	

CUSTOMER DRAWING